



帝科微
DIKEWEI

深圳市帝科微电子有限公司
DIKEWEI ELECTRONICS TECHNOLOGY, TLD. SHENZHEN

VDK 熔断保险丝

VDK FUSED FUSE



优良品质 · 诚信经营

一起携手 · 共创辉煌

www.dikewei.cn

VDKP1109 Mini Blade Fuse Devices

产品简介
DESCRIPTION

The VDKP1109 Mini Blade Fuses are the standard for vehicle circuit protection. Its miniature design meets the need for more circuits to be protected while utilizing less space, and its ability to cope with high temperatures in adverse environments makes the VDKP1109 Mini blade fuse of recommended choice for protection.

性能规格
PERFORMANCE SPECIFICATIONS

Model	Current Rating (A)	Interrupting Rating	Voltage Rating	Typ.Voltage Drop(mV)	Cold Resistance (mK)	Housing Material Color
VDKP1109-1A	1.0	1000A @32VDC	32V DC	225	64.0	灰绿色
VDKP1109-2A	2.0			200	36.6	灰色
VDKP1109-3A	3.0			175	31.24	紫色
VDKP1109-4A	4.0			175	23.5	玫瑰色
VDKP1109-5A	5.0			175	17.0	橙色
VDKP1109-7.5A	7.5			150	11.3	褐色
VDKP1109-10A	10.0			125	8.60	红色
VDKP1109-15A	15.0			125	6.25	浅蓝色
VDKP1109-20A	20.0			125	4.50	黄色
VDKP1109-25A	25.0			110	3.67	透明色
VDKP1109-30A	30.0			100	3.10	浅绿色
VDKP1109-35A	35.0			90	2.75	深紫色
VDKP1109-40A	40.0			85	2.43	粉红色

时间-电流特性
TIME CURRENT CHARACTERISTICS

% of Rating	Opening Time
110	4h min
135	0.75s~1800s
200	0.15s~5s
350	0.04s~0.5s
600	0.02~0.1s

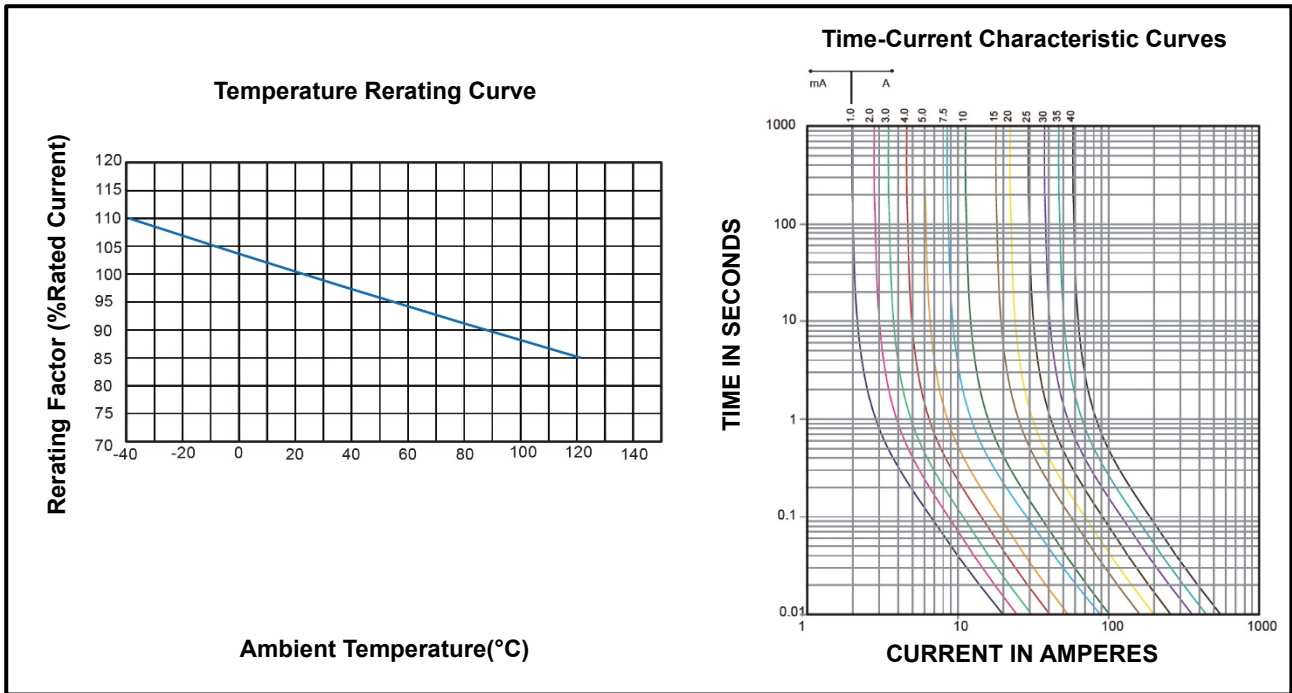
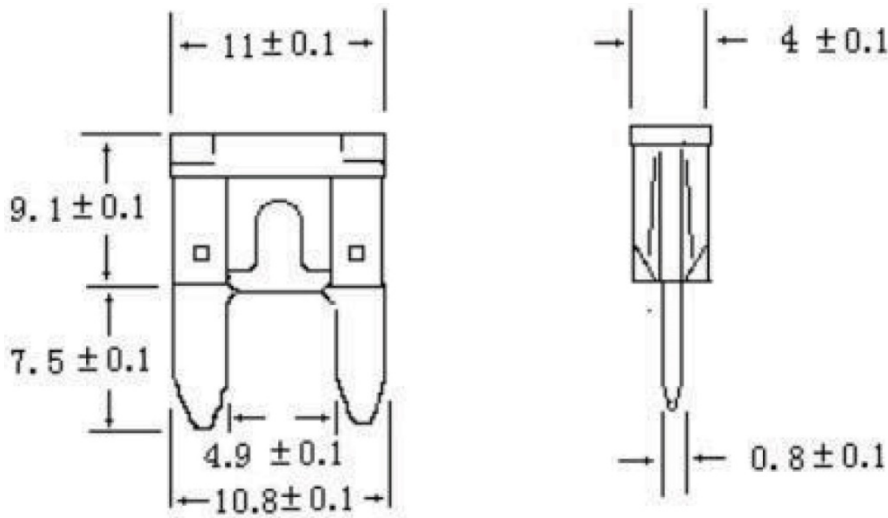
环境特性
ENVIRONMENTAL CHARACTERISTIC

外型尺寸
DIMENSIONS

产品规格
SPECIFICATION

Component level Temperature Range	-40°C~+125°C
System Level Temperature Range	-40°C~+105°C
Terminals	zinc alloy
Housing Material	PC

105°C and 85°C are typical system level temperature requirements.