

VDK 熔断保险丝

VDK FUSED FUSE



优良品质 · 诚信经营

一起携手 · 共创辉煌

VDKG5F GLASS TUBE FUSE

产品简介
DESCRIPTION

VDKG5F, Fast Acting glass tube fuse, suitable for various kinds of electronic devices' circuit over current protection. Widely used in industrial of Lighting, Power supply and Adapter applications, etc.

机构认证
AGENCY APPROVALS

AGENCY	FILE NUMBER
	E486200

外型尺寸
DIMENSIONS AND STRUCTURE

Unit: mm

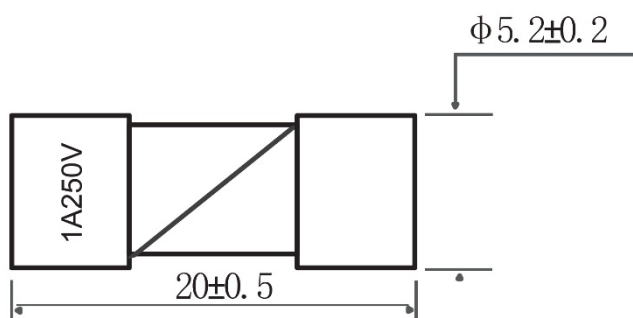
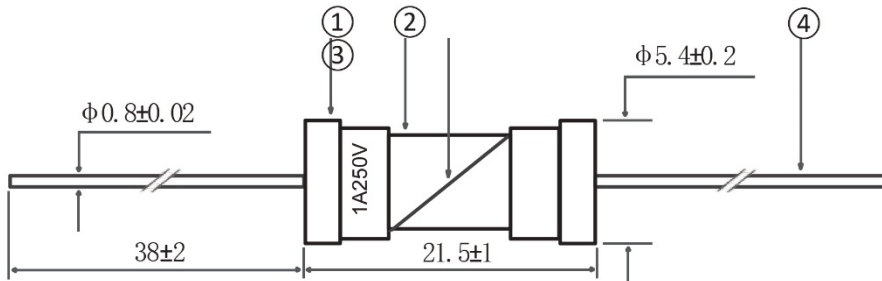

NO.	Part Name	Material
①	Cap	Nickel Plated Brass
②	Body	Glass Tube
③	Fuse element	Alloy
④	Lead wire	Tin Plated Copper

性能规格
PERFORMANCE SPECIFICATIONS

Model	Ampere Rating (A)	Voltage Rating (V)	Breaking Capacity	I ² T Melting Integral(A ² .S)
VDKG5F0100N/L	0.10			0.002
VDKG5F0125N/L	0.125			0.003
VDKG5F0160N/L	0.16			0.005
VDKG5F0200N/L	0.20			0.01
VDKG5F0250N/L	0.25			0.02
VDKG5F0300N/L	0.30			0.04
VDKG5F0315N/L	0.315			0.045
VDKG5F0350N/L	0.35			0.055
VDKG5F0400N/L	0.40		10000A@125VAC	0.07
VDKG5F0500N/L	0.50		(200mA ~ 10A);	0.10
VDKG5F0630N/L	0.63			0.20
VDKG5F0750N/L	0.75			0.35
VDKG5F0800N/L	0.80		35A @250VAC	0.45
VDKG5F1100N/L	1.00		(200mA ~ 1A);	0.90
VDKG5F1125N/L	1.25			1.30
VDKG5F1150N/L	1.50	250V/125V		1.60
VDKG5F1160N/L	1.60		100A @250VAC	2.50
VDKG5F1200N/L	2.00		(1.25A ~ 3.5A);	5.80
VDKG5F1250N/L	2.50			7.60
VDKG5F1300N/L	3.00			8.1
VDKG5F1315N/L	3.15		200A @250VAC	11
VDKG5F1350N/L	3.50		(4A ~ 10A).	19
VDKG5F1400N/L	4.00			28
VDKG5F1500N/L	5.00			40
VDKG5F1600N/L	6.00			50
VDKG5F1630N/L	6.30			64
VDKG5F1700N/L	7.00			107
VDKG5F1800N/L	8.00			133
VDKG5F2100N/L	10.0			242
VDKG5F2120N/L	12.0			-
VDKG5F2150N/L	15.0			-
VDKG5F2160N/L	16.0			670
VDKG5F2200N/L	20.0			700
VDKG5F2250N/L	25.0			850
VDKG5F2300N/L	30.0			1000

产品特性
PRODUCT CHARACTERISTICS

Item		Contain
Lead Pull Strength		5N for 10±1 Seconds
Lead Thrust Strength		2N for 10±1 Seconds
Solder ability	Wave	260°C, ≤3s;
	Soldering Iron	350±10°C, ≤3s
Soldering Heat Resistance	Wave	260°C, 10s
	Soldering Iron	350°C, 5s.

电气特点
ELECTRICAL CHARACTERISTICS

Test Condition	All electrical test is to be conducted with the ambient air at a temperature of 25±5°C
Load capacity	When the fuse loads through 100% of rated current, should blow within 4 hours.
Interrupting Rating Rising	Breaking Capacity: 10000A at 125VAC(200mA~10A); 35A at 250VAC(200mA~1A); 100A at 250VAC(1.25A~3.5A); 200A at 250VAC(4A~10A).
Temperature Test	When the 100% times of Ampere Rating passes the fuse, after reaching thermal balance, the temperature on the fuse surface rising shall not be higher than 75°C. Note: Rising temperature = the Surface temperature - Ambient temperature.

工作特性
OPERATING CHARACTERISTICS

% of Ampere Rating(In)	Blowing Time
100%*In	4 hours Min
200%*In	60 sec Max

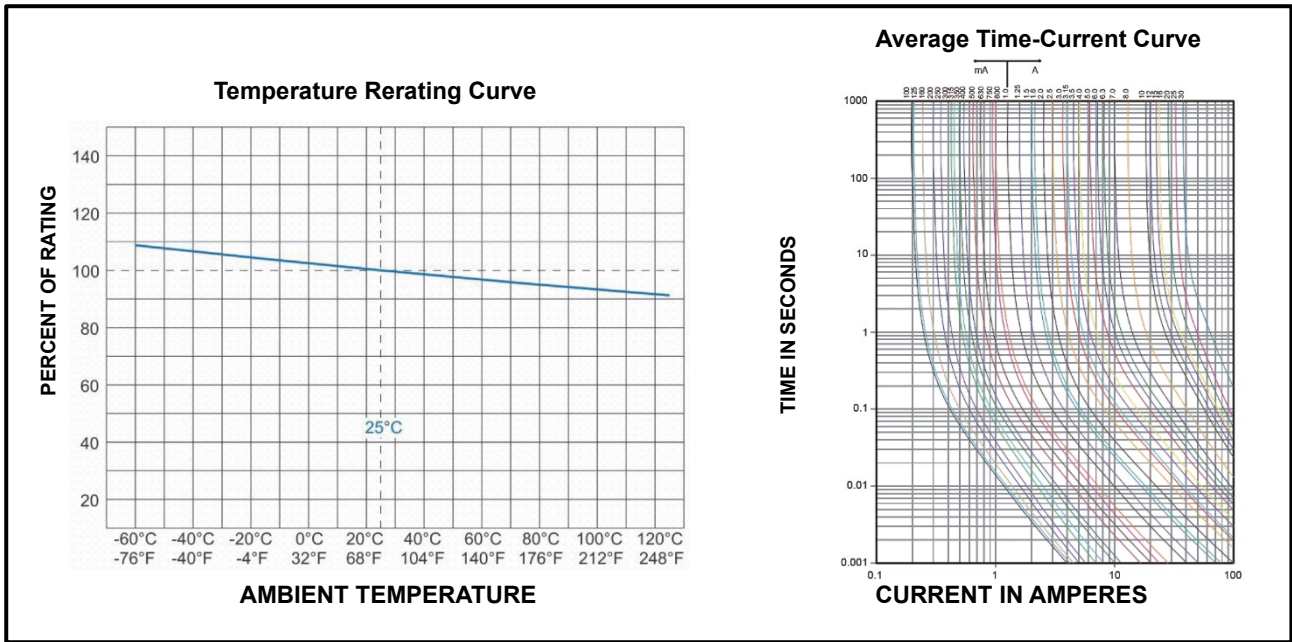
环境特性
ENVIRONMENTAL CHARACTERISTIC

When choosing the fuse's specification, if the operating environmental temperature beyond the scope from 20-30°C, engineer should consider the environmental temperature's affection to fuse. Please refer: Temperature Derating Curve:

Operating Temperature	-55°C~+125°C
Stock Condition	Humidity: Relative humidity ≤75% store 3 years in average

安装说明
INSTALLATION RECOMMENDATIONS

Propose installation way as following picture

A、卧式安装

Horizontal installation

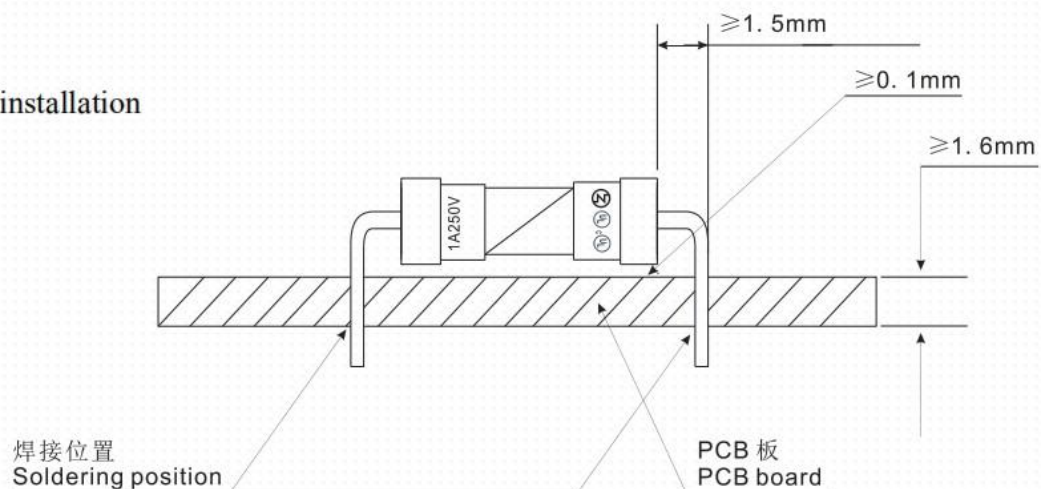

B、立式安装
 Vertical installation

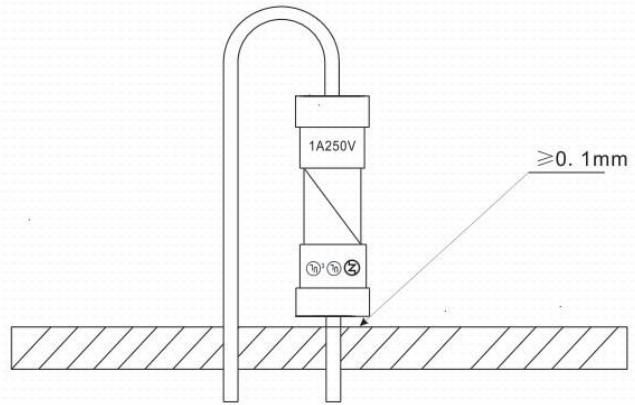

焊接参数 SOLDERING PARAMETERS

Recommended Soldering Parameters:

Recommended Soldering	Parameters
Wave Parameters	Solder Pot Temperature: 260°C Max
	Solder Dwell Time 2~5s
Hand-Solder Parameters	Solder Iron Temperature: 350±5°C
	Heating Time: 5s Max

产品编号 PART NUMBERING SYSTEM

VDK G 5F xxxx N/L

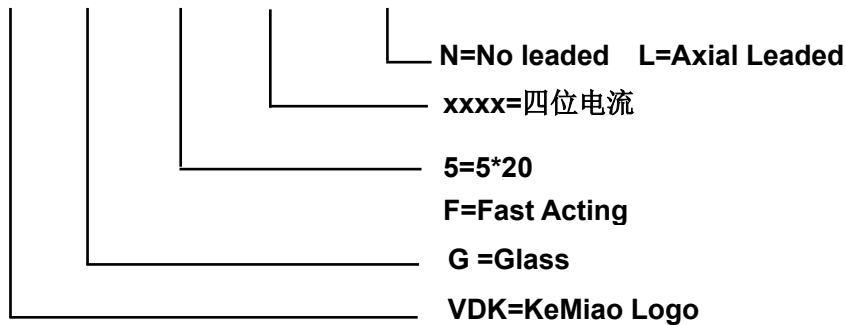

包装规格 PACKAGING QUANTITY AND MARKING

Packing	Quantity
Bag	250 pcs/poly bag
Box	10 poly bag/box
Outer carton	4 inner boxes/outer carton