

VDK 熔断保险丝

VDK FUSED FUSE



优良品质 · 诚信经营

一起携手 · 共创辉煌

VDKG3T GLASS TUBE FUSE

产品简介
DESCRIPTION

VDKG3T, Time-Lag glass tube fuse, suitable for various kinds of electronic devices' circuit over current protection. Widely used in industrial of Lighting, Power supply and Adapter applications, etc.

机构认证
AGENCY APPROVALS

AGENCY	FILE NUMBER
	E486200

外型尺寸
DIMENSIONS AND STRUCTURE

Unit: mm

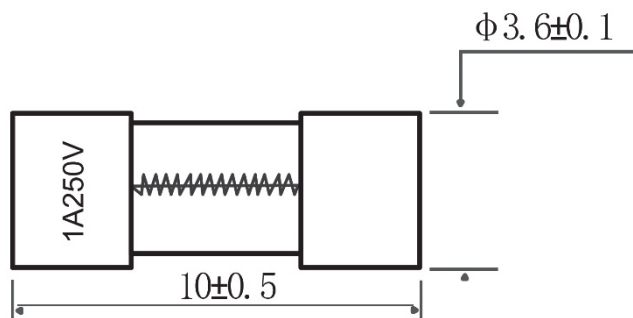
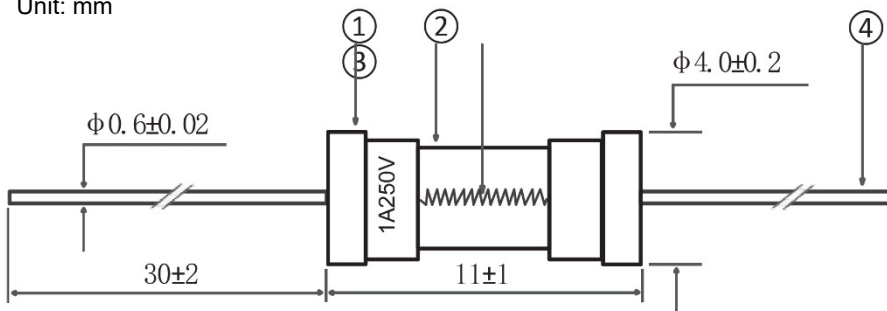

NO.	Part Name	Material
①	Cap	Nickel Plated Brass
②	Body	Glass Tube
③	Fuse element	Alloy
④	Lead wire	Tin Plated Copper

性能规格
PERFORMANCE SPECIFICATIONS

Model	Ampere Rating (A)	Voltage Rating (V)	Breaking Capacity	I ² T Melting Integral(A ² .S)
VDKG3T0100N/L	0.10			0.0042
VDKG3T0125N/L	0.125			0.010
VDKG3T0160N/L	0.16			0.025
VDKG3T0200N/L	0.20			0.035
VDKG3T0250N/L	0.25			0.056
VDKG3T0300N/L	0.30			0.10
VDKG3T0315N/L	0.315			0.12
VDKG3T0350N/L	0.35			0.15
VDKG3T0400N/L	0.40			0.25
VDKG3T0500N/L	0.50			0.35
VDKG3T0630N/L	0.63			0.55
VDKG3T0750N/L	0.75			0.70
VDKG3T0800N/L	0.80			1.1
VDKG3T1100N/L	1.00			2.0
VDKG3T1125N/L	1.25			3.8
VDKG3T1150N/L	1.50	250V	50A @250VAC	4.2
VDKG3T1160N/L	1.60			6.2
VDKG3T1200N/L	2.00			13
VDKG3T1250N/L	2.50			18
VDKG3T1300N/L	3.00			28
VDKG3T1315N/L	3.15			32
VDKG3T1350N/L	3.50			39
VDKG3T1400N/L	4.00			43
VDKG3T1500N/L	5.00			58
VDKG3T1600N/L	6.00			73
VDKG3T1630N/L	6.30			81
VDKG3T1700N/L	7.00			183
VDKG3T1800N/L	8.00			196
VDKG3T2100N/L	10.0			224
VDKG3T2120N/L	12.0			270
VDKG3T2150N/L	15.0			290
VDKG3T2160N/L	16.0			304
VDKG3T2200N/L	20.0			340

产品特性
PRODUCT CHARACTERISTICS

Item		Contain
Lead Pull Strength		5N for 10±1 Seconds
Lead Thrust Strength		2N for 10±1 Seconds
Solder ability	Wave	260°C, ≤3s;
	Soldering Iron	350±10°C, ≤3s
Soldering Heat Resistance	Wave	260°C, 10s
	Soldering Iron	350°C, 5s.

电气特点
ELECTRICAL CHARACTERISTICS

Test Condition	All electrical test is to be conducted with the ambient air at a temperature of 25±5°C
Load capacity	When the fuse loads through 100% of rated current, should blow within 4 hours.
Interrupting Rating	Breaking Capacity: 50A at 125V/250VAC.
Rising	When the 100% times of Ampere Rating passes the fuse, after reaching thermal balance, the temperature on the fuse surface rising shall not be higher than 75°C.
Temperature Test	Note: Rising temperature = the Surface temperature - Ambient temperature.

工作特性
OPERATING CHARACTERISTICS

% of Ampere Rating(In)	Blowing Time
100%*In	4 hours Min
200%*In	60 sec Max
1000%*In	10 ms Min

平均时间-电流曲线

AVERAGE TIME CURRENT CURVES

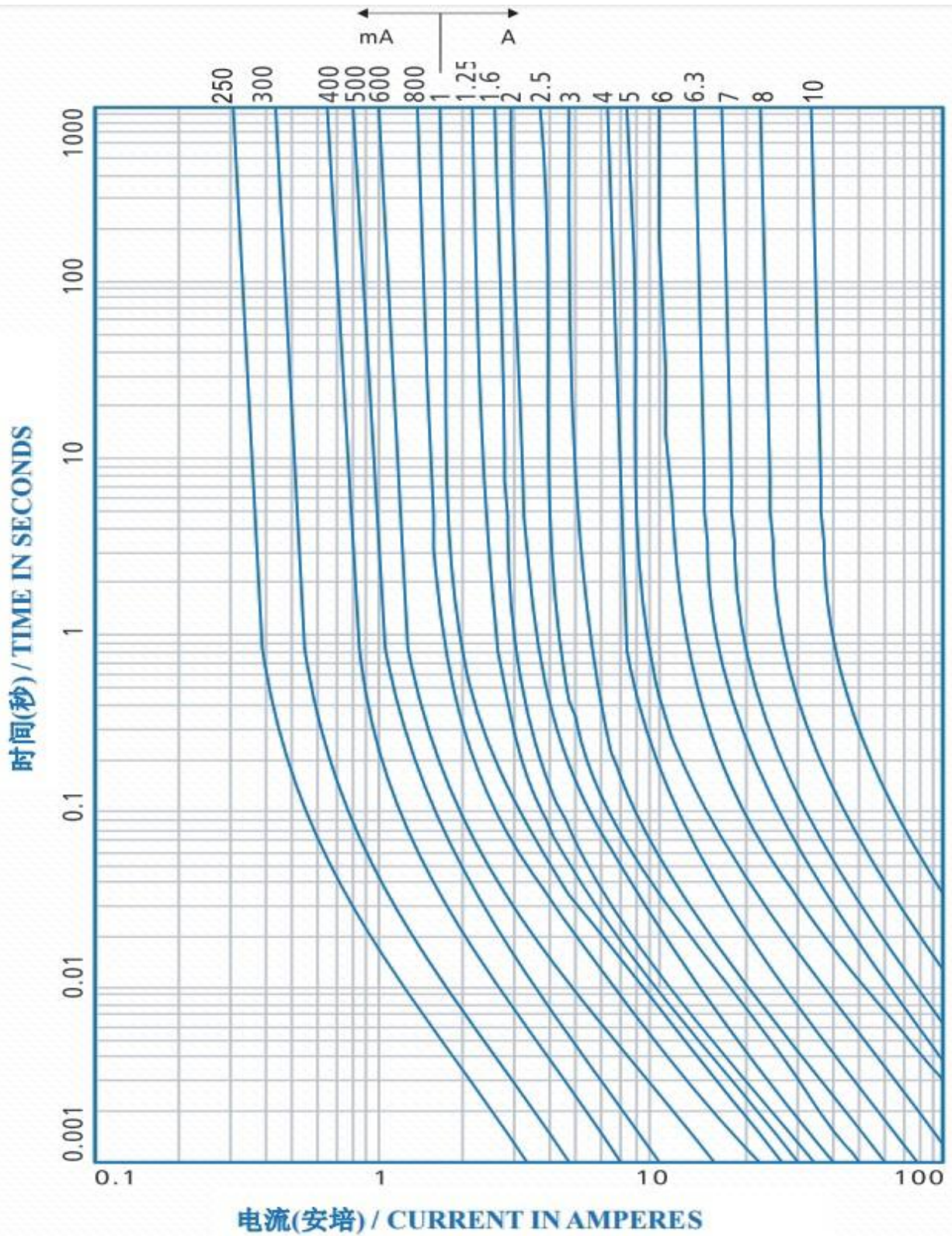

环境特性
ENVIRONMENTAL CHARACTERISTIC

Operating Temperature	-55°C~+125°C
Stock Condition	Humidity: Relative humidity ≤75% store 3 years in average

When choosing the fuse's specification, if the operating environmental temperature beyond the scope from 20-30°C, engineer should consider the environmental temperature's affection to fuse. Please refer: Temperature Rerating Curve:

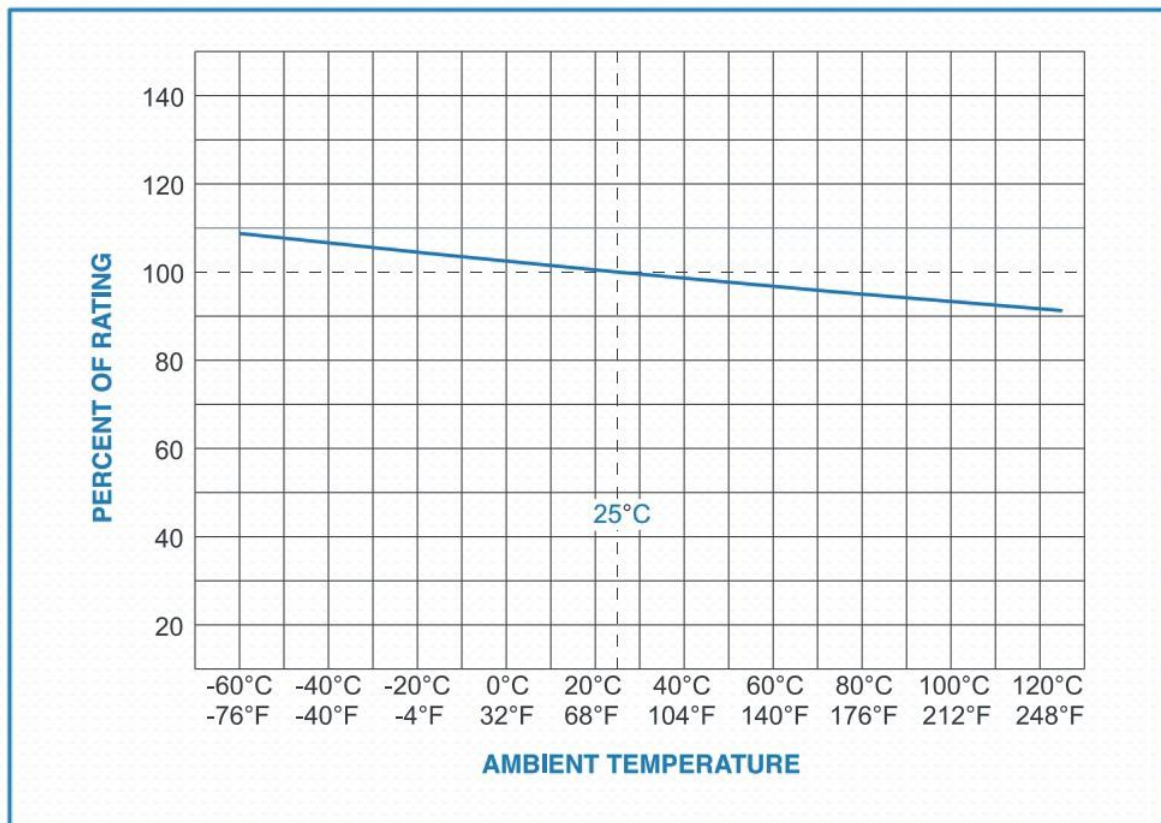
安装说明
INSTALLATION RECOMMENDATIONS

Propose installation way as following picture

A、卧式安装

Horizontal installation

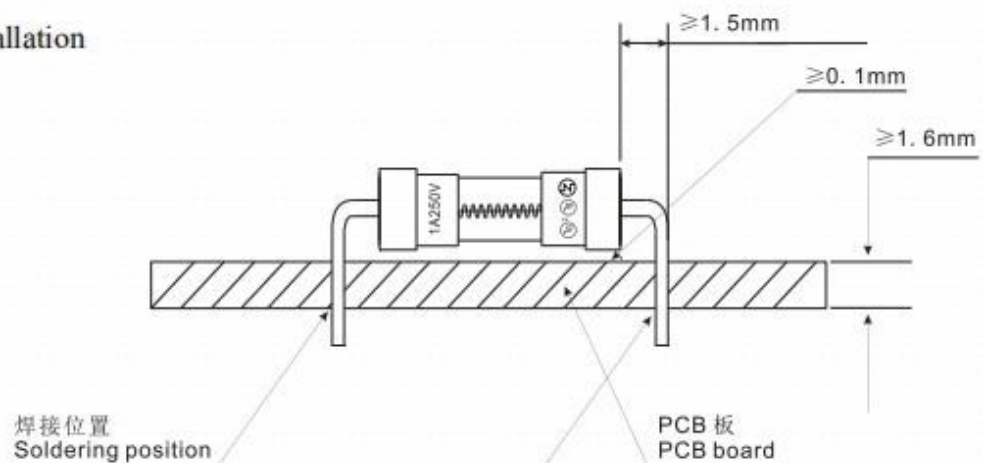

B、立式安装
Vertical installation

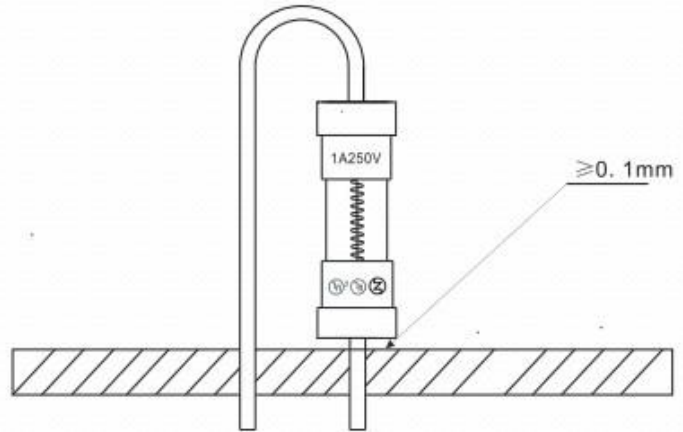

C、立式安装
Vertical installation

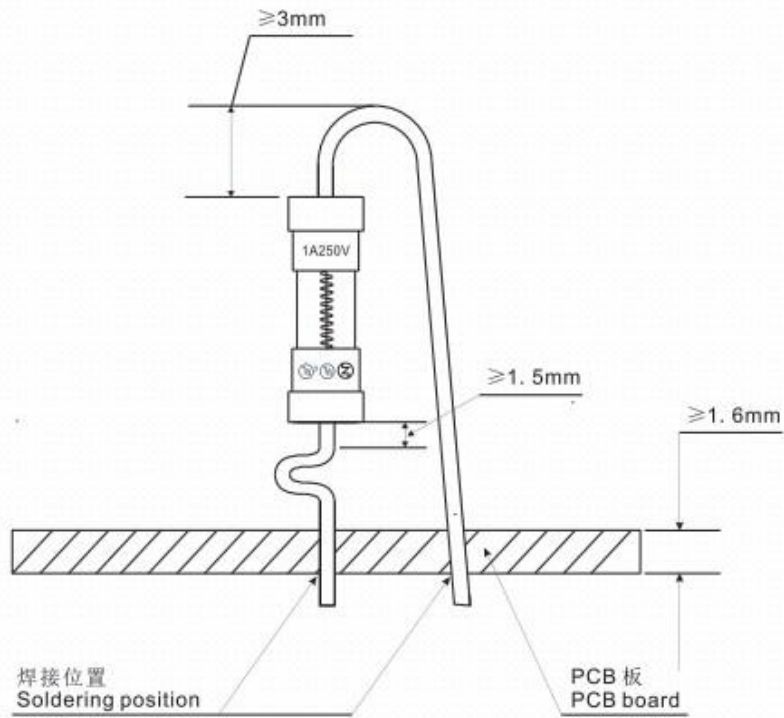

焊接参数

SOLDERING PARAMETERS

Recommended Soldering Parameters:

Recommended Soldering	Parameters
Wave Parameters	Solder Pot Temperature: 260°C Max
	Solder Dwell Time 2~5s
Hand-Solder Parameters	Solder Iron Temperature: 350±5°C
	Heating Time: 5s Max

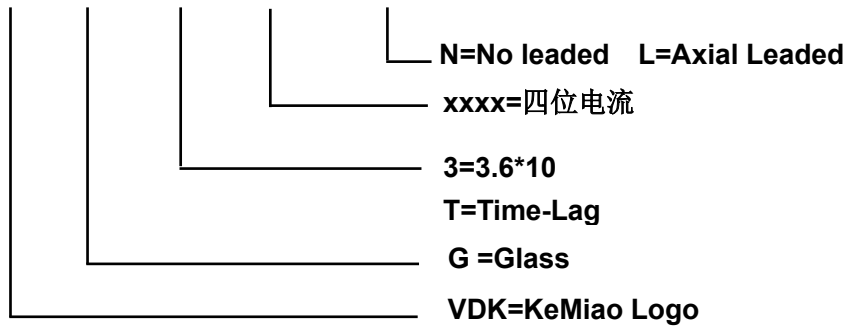
产品编号
PART NUMBERING SYSTEM
VDK G 3T xxxx N/L

包装规格
PACKAGING QUANTITY AND MARKING

Packing	Quantity
Bag	500 pcs/poly bag
Box	10 poly bag/box
Outer carton	4 inner boxes/outer carton