

电气特性
Performance Specification

Model	Marking	V _{max} (V _{dc})	I _{max} (A)	I _{hold} @25°C (A)	I _{trip} @25°C (A)	Pd Typ. (W)	Maximum Time To Trip		Resistance	
							Current (A)	Time (Sec)	Ri min (Ω)	R1 max (Ω)
SMD2018R030SF	R030	60	10	0.30	0.60	0.9	1.5	3.00	0.500	2.300
SMD2018R050SF	R050	60	10	0.55	1.20	1.0	2.5	3.00	0.200	1.000
SMD2018R075SF	R075	60	10	0.75	1.50	1.1	8.0	0.30	0.110	0.630
SMD2018R100SF	R100	15	35	1.10	2.20	1.1	8.0	0.40	0.060	0.360
SMD2018R100SF33V	R100	33	35	1.10	2.20	1.1	8.0	0.40	0.060	0.360
SMD2018R150SF	R150	15	35	1.50	3.00	1.1	8.0	0.80	0.050	0.170
SMD2018R200SF	R200	10	35	2.00	4.00	1.1	8.0	2.40	0.030	0.100

V_{max} = Maximum operating voltage device can withstand without damage at rated current (I_{max}).

I_{max} = Maximum fault current device can withstand without damage at rated voltage (V_{max}).

I_{hold} = Hold Current. Maximum current device will not trip in 25°C still air.

I_{trip} = Trip Current. Minimum current at which the device will always trip in 25°C still air.

Pd = Power dissipation when device is in the tripped state in 25°C still air environment at rated voltage.

Ri min/max = Minimum/Maximum device resistance prior to tripping at 25°C.

R1max = Maximum device resistance is measured one hour post reflow.

CAUTION: Operation beyond the specified ratings may result in damage and possible arcing and flame.



环境规范
Environmental Specifications

Test	Conditions	Resistance change
Passive aging	+85°C, 1000 hrs.	I HOLD/I TRIP PASS
Humidity aging	+85°C, 85% R.H. , 168 hours	I HOLD/I TRIP PASS
Thermal shock	+85°C to -40°C, 20 times	I HOLD/I TRIP PASS
Resistance to solvent	MIL-STD-202, Method 215	No change
Vibration	MIL-STD-202, Method 201	No change

Ambient operating conditions: -40°C ~+85°C

Maximum surface temperature of the device in the tripped state is 125°C

安规认证及环保检测
Agency Approval and Environmental Compliance

Agency	File Number	Regulation	Standard
UL	pending		2002/95/EC
TUV	pending		EN14582

热减载图表
Thermal Derating Chart

Recommended Hold Current(A) at Ambient Temperature(°C)

Model	Ambient Operation Temperature								
	-40°C	-20°C	0°C	25°C	40°C	50°C	60°C	70°C	85°C
SMD2018R030SF	0.48	0.42	0.35	0.30	0.24	0.21	0.17	0.15	0.10
SMD2018R050SF	0.87	0.77	0.67	0.55	0.46	0.41	0.36	0.31	0.23
SMD2018R075SF	1.19	1.05	0.91	0.75	0.61	0.54	0.47	0.41	0.32
SMD2018R100SF	1.71	1.52	1.32	1.10	0.94	0.84	0.74	0.64	0.50
SMD2018R150SF	2.38	2.10	1.82	1.50	1.27	1.13	0.99	0.85	0.64
SMD2018R200SF	2.95	2.65	2.35	2.00	1.74	1.59	1.44	1.29	1.06

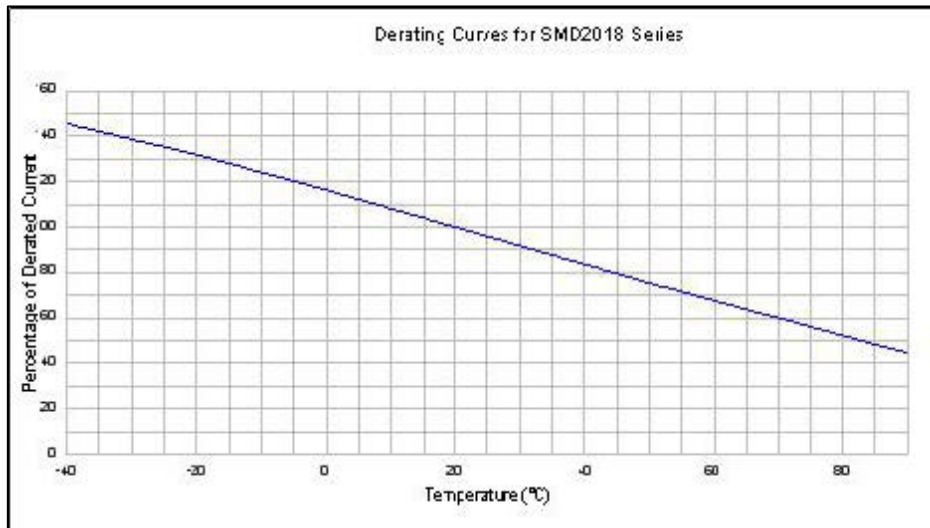
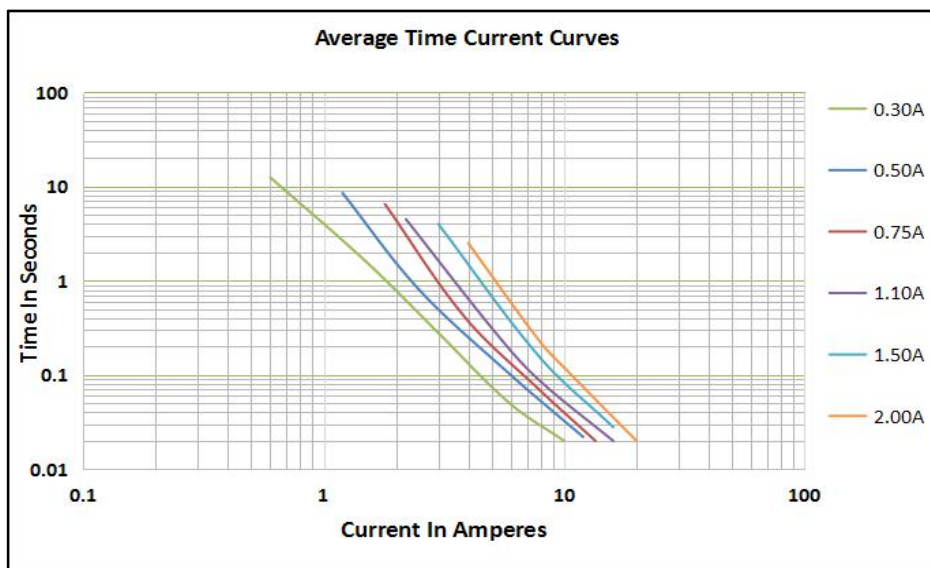
环境温度与工作电流关系特性图
Thermal Derating Curve

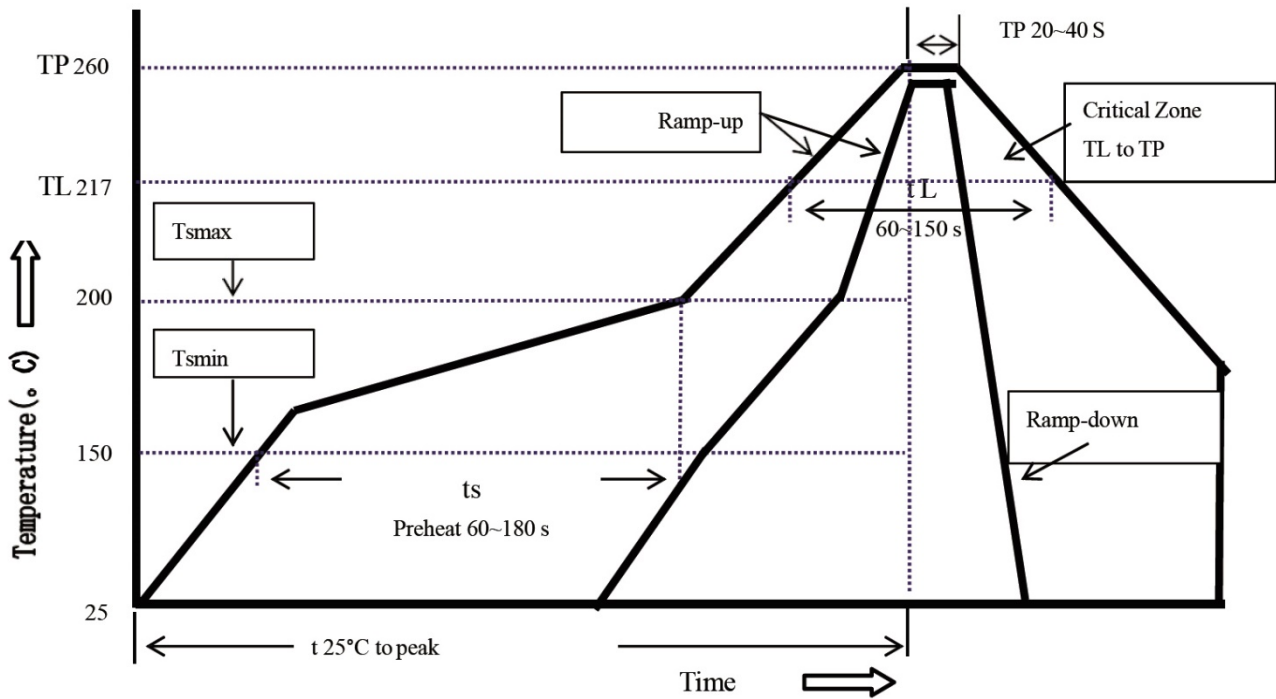
在 25°C 跳闸保护时间曲线表
Average Time-Current Curve

产品过炉焊接参数
Soldering Parameters

Profile Feature	Pb-Free Assembly
Average Ramp-Up Rate (Ts max to Tp)	3°C/second max.
Preheat	
-Temperature Min (Ts min)	150°C
-Temperature Max (Ts max)	200°C
-Time (Ts min to Ts max)	60~180 seconds
Time maintained above:	
-Temperature (TL)	217°C
-Time (tL)	60~150 seconds
Peak Temperature (Tp)	260°C
Ramp-Down Rate	6°C/second max.
Time 25°C to Peak Temperature	8 minutes max
Storage Condition	0°C~30°C, 30%-60% RH

Recommended reflow methods: IR, vapor phase oven, hot air oven, N2 environment for lead-free

Recommended maximum paste thickness is 0.25mm

Devices can be cleaned using standard industry methods and solvents.

Note 1: All temperature refer to topside of the package, measured on the package body surface.

Note 2: If reflow temperatures exceed the recommended profile, devices may not meet the performance requirements.

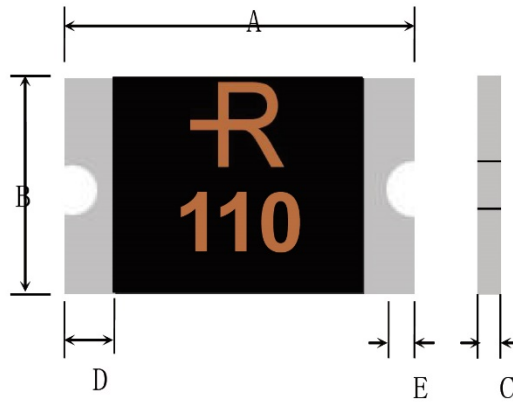
产品尺寸规格
Physical Dimensions

型号	A		B		C		D	E
	Min.	Max.	Min.	Max.	Min.	Max.	Min.	Min.
SMD2018R030SF	4.72	5.44	4.22	4.93	0.50	1.20	0.30	0.25
SMD2018R050SF	4.72	5.44	4.22	4.93	0.50	1.20	0.30	0.25
SMD2018R075SF	4.72	5.44	4.22	4.93	0.50	1.20	0.30	0.25
SMD2018R100SF	4.72	5.44	4.22	4.93	0.50	1.20	0.30	0.25
SMD2018R100SF33V	4.72	5.44	4.22	4.93	0.50	1.20	0.30	0.25
SMD2018R150SF	4.72	5.44	4.22	4.93	0.50	1.20	0.30	0.25
SMD2018R200SF	4.72	5.44	4.22	4.93	0.50	1.20	0.30	0.25
SMD2018R030SF	4.72	5.44	4.22	4.93	0.50	1.20	0.30	0.25
SMD2018R050SF	4.72	5.44	4.22	4.93	0.50	1.20	0.30	0.25

Termination pad Characteristics

Terminal pad materials: Tin-plated Nickel-Copper

Terminal pad solder ability: Meets EIA specification RS186-9E and ANSI/J-STD-002 Category 3

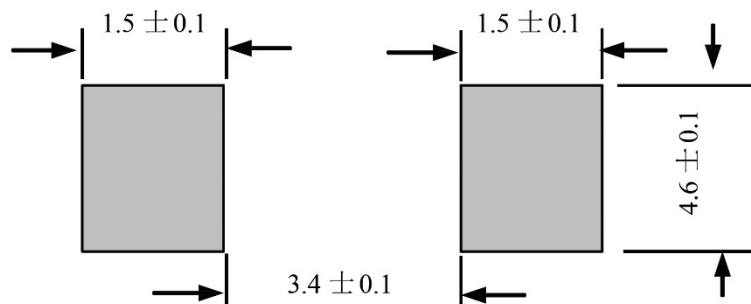
锡垫面推荐
Recommended Pad Layout (mm)

包装数量
Packaging Quantity

Part Number	Quantity
SMD2018R030 050SF	1,500 pcs/reel
The others	2,500 pcs/reel

Tape & reel packaging per EIA 481-1

胶带和卷筒规格
Tape And Reel Specifications (mm)

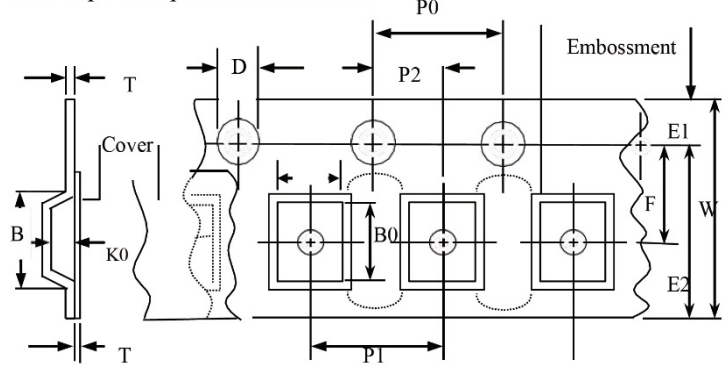
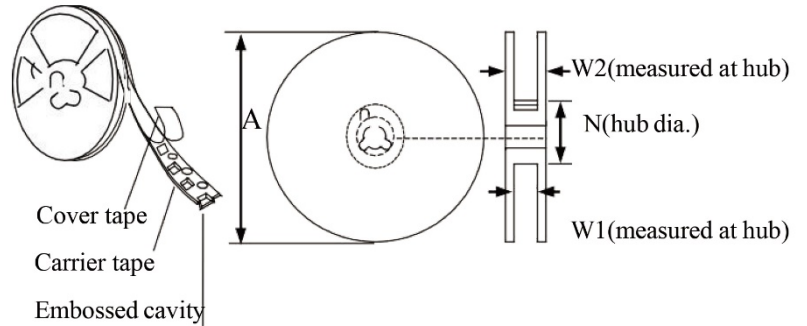
Governing Specifications	EIA 481-1
W	12.0 ± 0.2
P ₀	4.0 ± 0.10
P ₁	8.0 ± 0.10
P ₂	2.0 ± 0.05
A ₀	4.40 ± 0.10
B ₀	5.50 ± 0.10
B _{1max}	8.20
D ₀	1.50 + 0.1, -0
F	5.5 ± 0.05
E ₁	1.75 ± 0.10
E _{2min.}	10.25
T	0.6
T _{1max.}	0.1
K ₀	1.36 ± 0.1
Leader min.	390
Trailer min.	160
Reel Dimensions	
A max.	178
N min.	50
W ₁	12.4 ± 0.5
W ₂	18.4 ± 0.5

EIA Tape Component Dimensions

EIA Reel Dimensions

Storage And Handling

·Storage Conditions: 0°C~30°C, 30%~60% R.H.

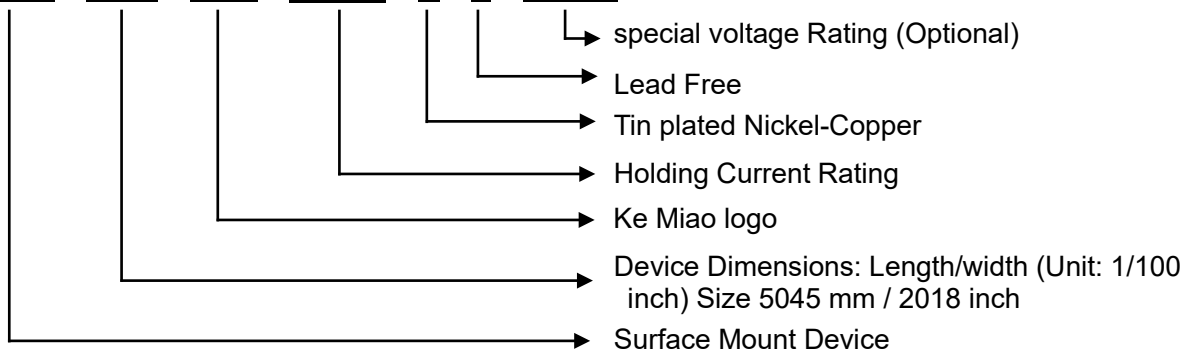
·Devices may not meet specified performance

if storage conditions are exceeded.

包装数量
Part Number System
SMD 2018 VDK □□□ S F □□ V

注意事项

Others

PPTC 使用注意事项:

- PPTC 为热敏元件，对环境温度比较敏感，建议在 PPTC 周围不要设计热源元件，尽量减少外部热源的影响。
- 请在规格书规定的参数下使用，超出电压电流规格值，会导致 PPTC 出现电弧，阻值升高，甚至烧片。
- 规格书的电气特性，均是基于在大容指定测试板经过一次回流焊之后的测试；如果客户有二次回流焊或者注塑点胶等其他热工序，会对上述参数有一定程度的衰减，需要验证其适用性。
- PPTC 贴片产品是为 SMT 工艺设计的封装形式，焊接工艺为回流焊；要求客户遵守我们推荐的焊盘布局和回流焊配置文件。不正确的电路板布局或回流配置可能会对 PPTC 的可焊性性能产生负面影响。焊接工艺可参考大容推荐的回流焊曲线。如果回流焊温度超过推荐的值，PPTC 将有可能受到损伤。使用手工焊及波峰焊接 PPTC 可能会导致产品焊后电阻超出规格。
- 某些注塑料、单组份、双组份固化胶粘剂、硅胶、侵蚀性溶剂污染 PPTC 材料破坏芯片，需要对注塑料胶料等材料牌号以及应用参数（如温度、时间等）进行验证，以确保产品及工艺的匹配性，确认不会影响 PPTC 性能之后方可使用。PPTC 在充电线端应用中，建议使用 PP 类材料做内膜，禁止使用 TPE 类与 PVC 类等材料做内膜。
- PPTC 贴装或使用过程中，不建议使用洗板水或其他清洗剂进行清洗。如必须使用，需要验证各类清洗剂、洗板水以及溶剂的适用性，确认不会影响 PPTC 性能之后方可使用。已知对 PPTC 有影响的化学药品包括但不限于醚类、苯类、酮类以及脂类等较强溶解性、破坏性的有机化合物，清洗后将产品放置于敞开的环境中至少 24 小时，将残留的溶剂进行充分的挥发。
- 装配过程中，避免用暴力砸、挤、压、拉、扭、刺等方式作用 PPTC 本体，以免引起 PPTC 性能衰减。
- PPTC 元件是为电路中偶尔出现的过流而设计的，不建议用在连续且持续过流的电路中。
- 大容 SMD PPTC 湿敏等级为 2 级，为密封包装。客户如在库存中发现有包装破损的，立即将产品隔离处理；使用时如有余料，需恢复之前包装状态，做密封保存，否则会影响产品性能导致焊后电阻越规格。
- 产品废弃时，可按照一般电子废弃物处理，具体材料组成可参见 MSDS

Precautions for PPTC use:

- PPTC is a thermal element, which is more sensitive to ambient temperature. It is recommended not to design heat source elements around PPTC to minimize the influence of external heat sources.
- Please use it under the parameters specified in the specification. Exceeding the voltage

and current specifications will cause the PPTC to arc, increase the resistance, and even burn the chip.

- The electrical characteristics of the specification are all based on the test after a reflow soldering on the designated test board of Darong; if the customer has other thermal processes such as secondary reflow soldering or injection molding, the above parameters will be attenuated to a certain extent. Need to verify its applicability.
- PPTC SMD products are package forms designed for SMT process, and the soldering process is reflow soldering; customers are required to comply with our recommended land layout and reflow soldering profile. Incorrect circuit board layout or reflow configuration may negatively affect the solderability performance of PPTC. For the soldering process, please refer to the reflow soldering curve recommended by Darong. If the reflow temperature exceeds the recommended value, PPTC may be damaged. The use of manual soldering and wave soldering PPTC may cause the resistance of the product to exceed specifications after welding.
- Certain injection molding compounds, one-component, two-component curing adhesives, silica gel, and aggressive solvents contaminate PPTC materials to destroy the chip. It is necessary to verify the material grades and application parameters (such as temperature, time, etc.) of the injection molding compound to ensure. The compatibility of the product and process can be used after confirming that it will not affect the performance of PPTC. In the application of PPTC at the end of the charging cable, it is recommended to use PP materials as the inner membrane, and it is forbidden to use TPE and PVC materials as the inner membrane.
- It is not recommended to use plate washer water or other cleaning agents for cleaning during PPTC placement or use. If it must be used, it is necessary to verify the applicability of various cleaning agents, washing water and solvents, and confirm that it will not affect the performance of PPTC before use. Chemicals known to affect PPTC include, but are not limited to, more soluble and destructive organic compounds such as ethers, benzenes, ketones, and lipids. After cleaning, place the product in an open environment for at least 24 hours. Fully volatilize the remaining solvent.
- During the assembly process, avoid violently smashing, squeezing, pressing, pulling, twisting, puncturing the PPTC body, so as not to cause PPTC performance degradation.
- The PPTC component is designed for occasional overcurrent in the circuit, and it is not recommended to be used in a continuous and continuous overcurrent circuit.
- Darong SMD PPTC has a moisture sensitivity level of 2 and is a sealed package. If the customer finds any packaging damage in the inventory, immediately isolate the product; if there is excess material during use, it must be restored to the previous packaging state and sealed and stored, otherwise it will affect the product performance and cause the resistance after welding to exceed the specifications.
- When the product is discarded, it can be treated as general electronic waste, and the specific material composition can be found in MSDS