

# 30R HF 系列 PTC产品

## 30R HF Series PTC Devices

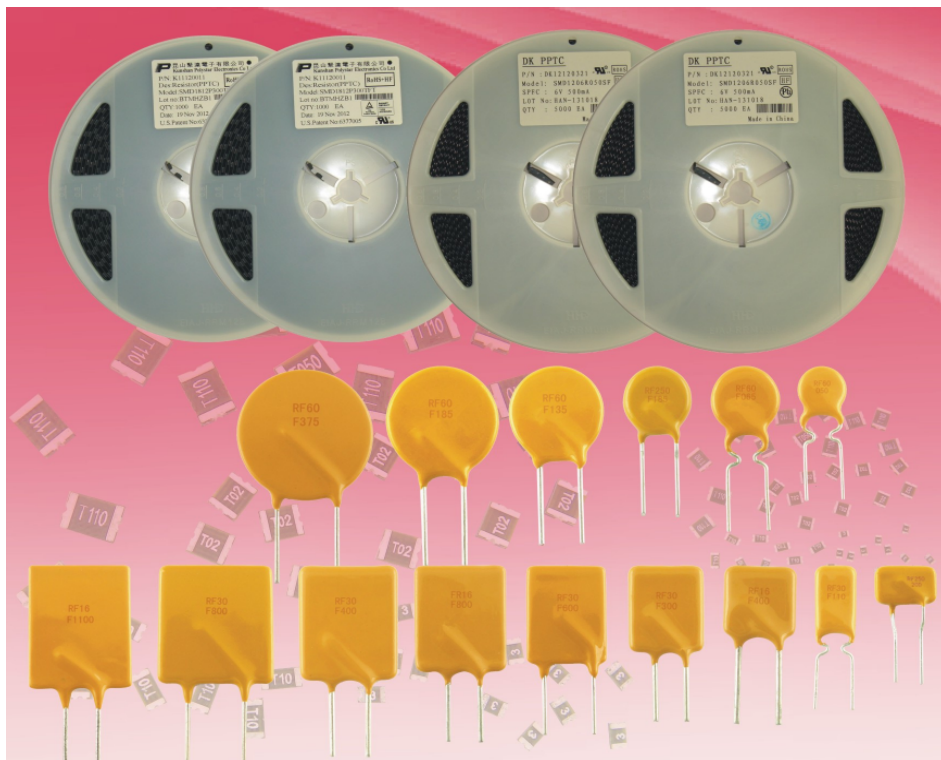

优良品质 · 诚信经营

一起携手 · 共创辉煌

**电气特性**
**Performance Specification**

Model	V <sub>max</sub> (V <sub>dc</sub> )	I <sub>max</sub> (A)	I <sub>hold</sub> (A)	I <sub>trip</sub> (A)	Pd Typ. (w)	Maximum Time To Trip		Resistance		
						Current (A)	Time (Sec)	Ri min (Ω)	Ri max (Ω)	R1 max (Ω)
30R050	30	40	0.50	1.00	0.50	8.00	0.3	0.230	0.450	0.730
30R065	30	40	0.65	1.30	0.50	8.00	0.4	0.160	0.350	0.550
30R075	30	40	0.75	1.50	0.88	8.0	0.4	0.160	0.280	0.420
30R090	30	40	0.90	1.80	0.91	4.50	5.9	0.120	0.230	0.360
30R110	30	40	1.10	2.20	1.00	5.50	6.6	0.090	0.180	0.270
30R135	30	40	1.35	2.70	1.11	6.75	7.3	0.075	0.130	0.195
30R160	30	40	1.60	3.20	1.20	8.00	8.0	0.050	0.110	0.165
30R185	30	40	1.85	3.70	1.27	9.25	8.7	0.040	0.100	0.150
30R200	30	40	2.00	4.00	1.30	12.5	10.3	0.038	0.070	0.105
30R250	30	40	2.50	5.00	1.34	12.5	10.8	0.025	0.060	0.097
30R300	30	40	3.00	6.00	2.00	15.0	10.8	0.020	0.055	0.085
30R400	30	40	4.00	8.00	2.50	20.0	12.7	0.010	0.040	0.060
30R500	30	40	5.00	10.00	3.00	25.0	14.5	0.010	0.035	0.052
30R600	30	40	6.00	12.00	3.50	30.0	16.0	0.008	0.025	0.038
30R700	30	40	7.00	14.00	3.80	35.0	17.5	0.005	0.020	0.030
30R800	30	40	8.00	16.00	4.00	40.0	18.8	0.005	0.0135	0.020
30R900	30	40	9.00	18.00	4.20	40.0	20.0	0.004	0.0105	0.020

V<sub>max</sub> = Maximum operating voltage device can withstand without damage at rated current (I<sub>max</sub>).

I<sub>max</sub> = Maximum fault current device can withstand without damage at rated voltage (V<sub>max</sub>).

I<sub>hold</sub> = Hold Current. Maximum current device will not trip in 25°C still air.

I<sub>trip</sub> = Trip Current. Minimum current at which the device will always trip in 25°C still air.

Pd = Power dissipation when device is in the tripped state in 25°C still air environment at rated voltage.

Ri min/max = Minimum/Maximum device resistance prior to tripping at 25°C.

R1max = Maximum device resistance is measured one hour post reflow.



**CAUTION:** Operation beyond the specified ratings may result in damage and possible arcing and flame.

**环境规范**
**Environmental Specifications**

Test	Conditions	Resistance change
Passive aging	+85°C, 1000 hrs.	±5% typical
Humidity aging	+85°C, 85% R.H. , 168 hours	±5% typical
Thermal shock	+85°C to -40°C, 20 times	±33% typical
Resistance to solvent	MIL-STD-202, Method215	No change
Vibration	MIL-STD-202, Method 201	No change
Ambient operating conditions: -40°C ~+85°C		
Maximum surface temperature of the device in the tripped state is 125°C		

安规认证及环保检测

Agency Approval and Environmental Compliance

Agency	File Number	Regulation	Standard
UL	pending		2002/95/EC
TUV	pending		EN14582

环境温度与工作电流关系特性图

Thermal Derating Curve

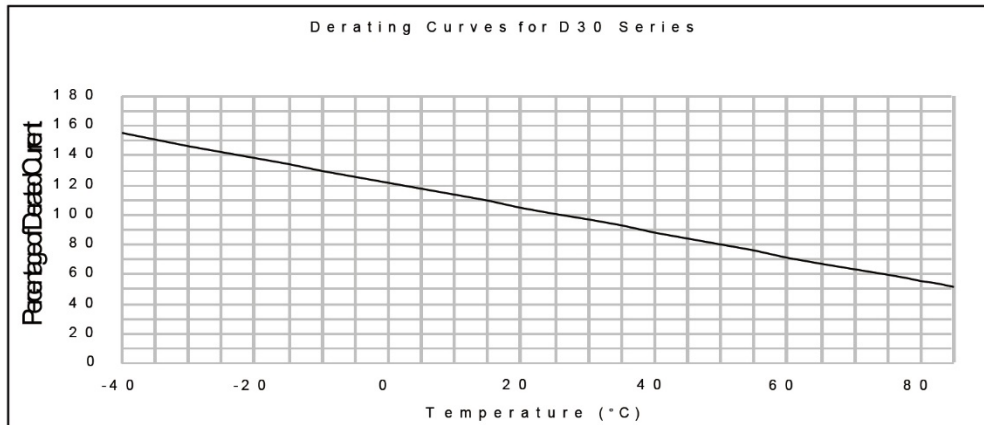

在 25°C 跳闸保护时间曲线表

Average Time-Current Curve

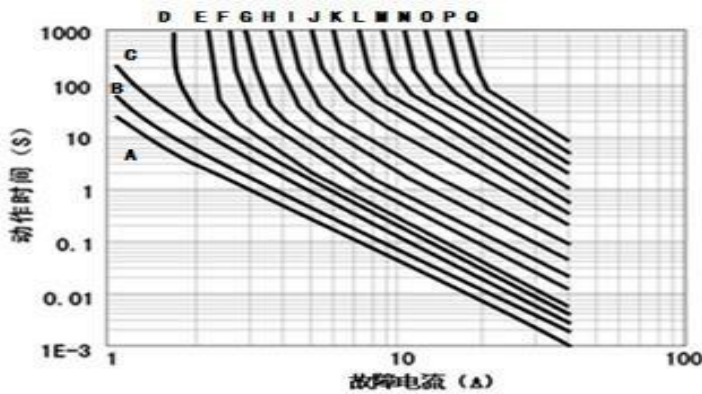

- A=30-050      B=30-065      O=30-700
- C=30-075      D=30-090      P=30-800
- E=30-110      F=30-135      Q=30-900
- G=30-160      H=30-185
- I=30-200      J=30-250
- K=30-300      L=30-400
- M=30-500      N=30-600

**PPTC 在不同环境温度下的保持电流(I hold)值**
**I Hold Versus Temperature**

Model	Maximum ambient operating temperature (T <sub>mao</sub> ) vs. hold current (I <sub>hold</sub> )								
	-40°C	-20°C	0°C	25°C	40°C	50°C	60°C	70°C	85°C
30R050	0.68	0.62	0.56	0.50	0.44	0.40	0.36	0.34	0.28
30R065	0.95	0.84	0.76	0.65	0.60	0.54	0.50	0.40	0.31
30R075	1.07	0.97	0.87	0.75	0.66	0.61	0.56	0.51	0.44
30R090	1.40	1.25	1.10	0.90	0.75	0.69	0.65	0.60	0.50
30R110	1.75	1.52	1.33	1.10	0.99	0.90	0.80	0.73	0.63
30R135	2.15	1.94	1.70	1.35	1.20	1.14	1.00	0.90	0.81
30R160	2.49	2.21	1.94	1.60	1.42	1.31	1.19	1.03	0.88
30R185	2.87	2.59	2.28	1.85	1.63	1.52	1.33	1.21	1.05
30R200	2.95	2.69	2.38	2.00	1.73	1.62	1.43	1.25	1.09
30R250	3.82	3.44	3.03	2.50	2.17	2.00	1.81	1.59	1.39
30R300	4.55	4.10	3.60	3.00	2.65	2.51	2.24	2.01	1.74
30R400	6.00	5.40	4.74	4.00	3.47	3.28	2.82	2.63	2.26
30R500	7.44	6.68	5.80	5.00	4.30	4.03	3.58	3.22	2.77
30R600	8.90	7.99	7.08	6.00	5.13	4.82	4.27	3.84	3.30
30R700	10.35	9.30	8.21	7.00	5.95	5.58	4.96	4.46	3.84
30R800	11.60	10.60	9.35	8.00	6.79	6.36	5.64	5.07	4.36
30R900	13.25	11.90	10.49	9.00	7.53	7.12	6.32	5.69	4.88

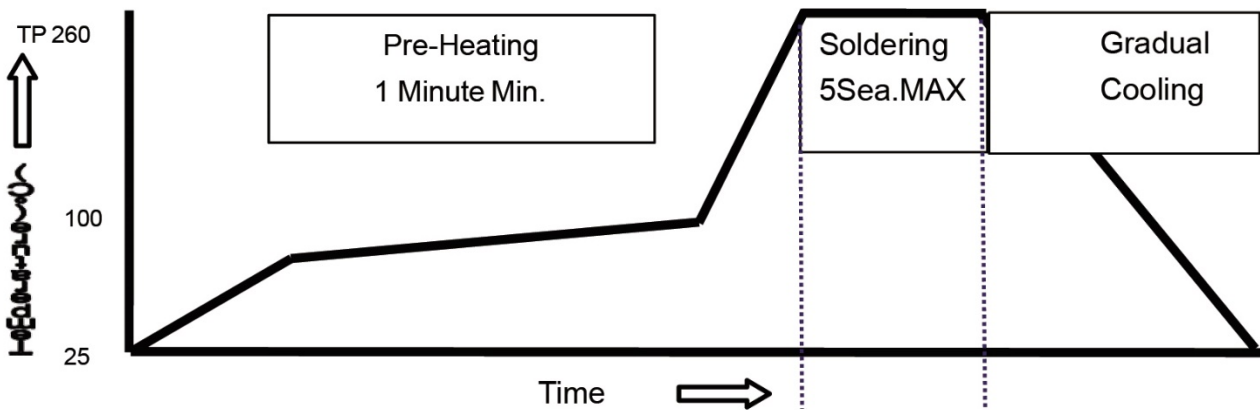
**产品过炉焊接参数**
**Soldering Parameters**

**WAVE SOLDERING INFORMATIONS**

Pre-Heating Zone	Max. ramping rate should not exceed 4°C/Sec.
Soldering Zone	Max. solder temperature should not exceed 260°C
Cooling Zone	Cooling by natural convection in air.

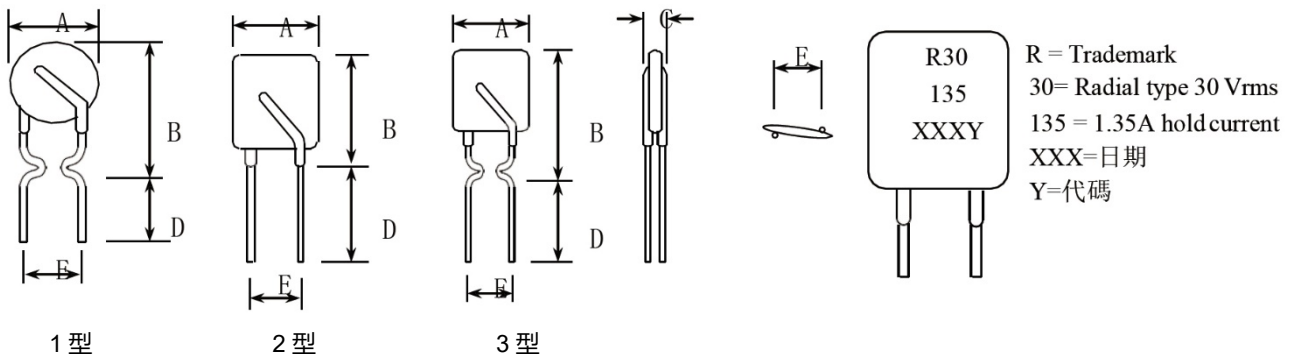
© Specifications are subject to change without notice.

**产品尺寸规格**
**Physical Dimensions**

Model	A Max.	B Max.	C Max.	D Min.	E Typ.	Lead	
						Style	直径(Φ)
30R050	6.4	12.4	3.1	7.6	5.1	1	0.5
30R065	6.4	12.4	3.1	7.6	5.1	1	0.5
30R075	7.6	14	3.1	7.6	5.1	1	0.6
30R090	7.4	14.8	3.1	7.6	5.1	3	0.6
30R110	7.8	15.0	3.1	7.6	5.1	3	0.6
30R135	8.9	14.5	3.1	7.6	5.1	3	0.6
30R160	9.7	17.0	3.1	7.6	5.1	3	0.6
30R185	10.7	17.0	3.1	7.6	5.1	3	0.6
30R200	11.5	19.0	3.1	7.6	5.1	3	0.6
30R250	11.7	19.0	3.1	7.6	5.1	3	0.6
30R300	11.7	17.5	3.1	7.6	5.1	2	0.8
30R400	14.6	19.9	3.1	7.6	5.1	2	0.8
30R500	18.0	21.0	3.1	7.6	10.2	2	0.8
30R600	17.0	24.0	3.1	7.6	10.2	2	0.8
30R700	22.0	27.5	3.1	7.6	10.2	2	0.8
30R800	25.0	28.5	3.0	7.6	10.2	2	0.8
30R900	27.0	30.5	3.0	7.6	10.2	2	0.8

**PHYSICAL SPECIFICATIONS:**

Materials: Leads 30R050~ 065: Tin-platedcopper-cladsteel, 0.205mm<sup>2</sup>(24AWG) Φ0.50 mm(0.020 in).

30R075~ 250: Tin-platedcopper-cladsteel, 0.205mm<sup>2</sup>(24AWG) Φ0.60 mm(0.020 in).

30R300~900 :Tin-plated copper 0.52mm<sup>2</sup>(24AWG), Φ0.80 mm(0.020 in).

Lead Solderability: MIL-STD-202, Method 208E

Device Labeling: Device is marked with Logo, amperage rating , voltage rating & date code.

**包装数量**
**Packaging Quantity**

30	135	U	Model	Reel Q'ty	Bag Q'ty
Radial type	Hold	U= Bulk	30R050~900	-	500
30V	Current(A)	packaged			

Tape & Reel packaging per EIA468-B standard.